



# SMART SENSOR INNOVATIONS FOR CDU QUALITY

*Pyxis Smart Sensors for AI Critical Coolant Distribution Systems*

## AI CRITICAL COOLING OVERVIEW

Data center cooling for artificial intelligence (AI) servers is a critical aspect of modern infrastructure, driven by the increasing computational demands of AI workloads. AI servers, particularly those running machine learning models and high-performance computing tasks, generate significant heat due to their dense configurations and high-power components, such as GPUs and TPUs. Traditional air-based cooling methods often struggle to keep up with these thermal loads, leading to the adoption of more advanced cooling technologies. Liquid cooling, including direct-to-chip and immersion cooling, has emerged as a preferred solution, offering superior heat dissipation and improved energy efficiency. These methods allow for higher server density, reduced energy consumption, and lower operational costs, making them essential for AI-driven data centers.

The rapid growth of AI applications, such as generative AI, large language models, and real-time analytics, has intensified the need for efficient cooling systems to maintain optimal performance and hardware longevity. In response, data center operators are investing in sustainable cooling strategies, including the use of renewable energy sources, AI-driven cooling management systems, and heat recycling technologies. Additionally, innovations like rear-door heat exchangers and hybrid cooling systems are gaining traction to balance efficiency with scalability. As AI server demand continues to rise, effective cooling will remain a key factor in ensuring reliability, minimizing downtime, and reducing the environmental impact of data centers.



## AI COOLING FLUID QUALITY - KPIs

Critical cooling fluid measurements are essential for ensuring the efficient and reliable operation of AI servers in data centers. These measures help monitor and control the cooling system, preventing overheating and maintaining optimal performance.

Industry guidelines (i.e. ASHRAE and others) for fluid quality in critical cooling systems for AI data centers emphasize maintaining optimal water chemistry to ensure long-term reliability and efficiency. Key parameters include:

## pH Balance

Maintaining a neutral or slightly alkaline pH (typically between 7.0 and 9.0) to prevent corrosion or scaling in cooling loops.

## Turbidity Control

Low turbidity levels are essential and critical to quality, as high turbidity can reduce heat transfer efficiency and lead to fouling of heat exchangers.

## Conductivity Monitoring

Conductivity is monitored to manage dissolved solids that can contribute to scaling or corrosion.

## Control acidification

The PG/EG coolant needs to be closely monitored for acidification or freezing point. An excessively low concentration of PG/EG will lead to the proliferation of microorganisms.

## Corrosion/Deposit Inhibitor Residual Control

Maintaining the proper residual of fluid treatment corrosion, deposit and freeze control levels can be a critical element in the fluid quality management program.

## Corrosion Rate Monitoring

Realtime monitoring and reporting of general and localized corrosion via LPR (linear polarization resistance) technology is a key performance indicator in AI critical cooling water systems.

Additionally, ASHRAE recommends using a Coolant Distribution Unit (CDU) to segregate the facility water system (FWS) from the technology cooling system (TCS), improving thermal control and preventing contamination. Regular monitoring and transient modeling are encouraged to predict performance under varying loads and ensure system resilience, especially as AI workloads push chip power and thermal demands into uncharted territory.

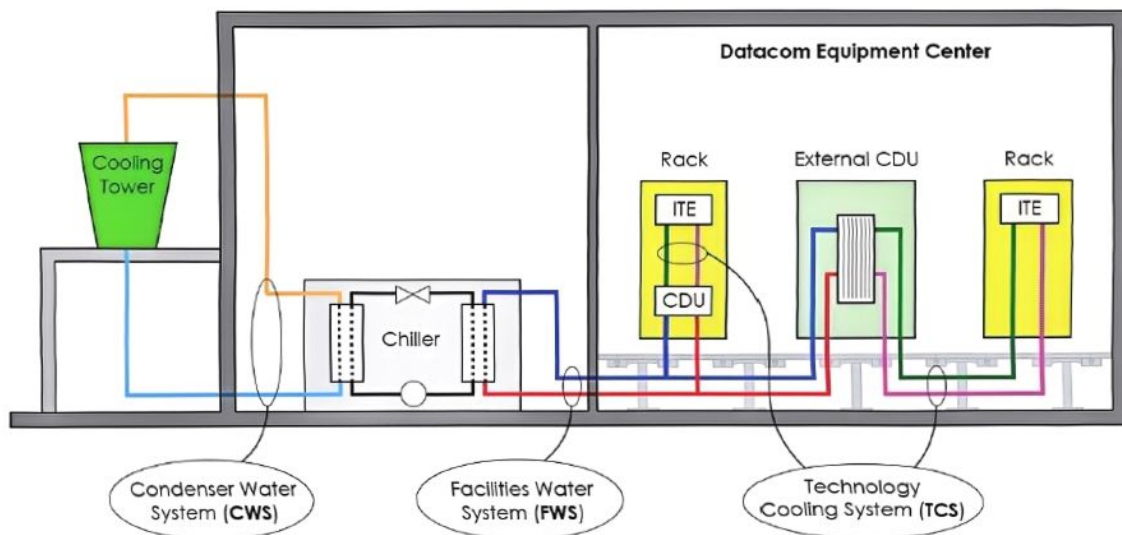

Figure 1 – Water-Cooled Servers (Image provided by ASHRAE Technical Committee 9.9)

## Pyxis Lab® Smart Sensor Innovations

Pyxis Lab, Inc. specializes in developing and producing advanced water monitoring technologies. The company is a leading manufacturer of specialized 'smart' inline sensors, handheld analytical devices, and fluorescent tracing chemicals used across various industries and markets to include critical coolant distribution systems to AI servers. Their technology focuses on improving water treatment operations by offering expanded detection ranges, lower detection limits, and user-friendly interfaces capable of direct communication from sensor to Network or PLC via integrated 4-20mA and RS-485 protocol. With global headquarters near Houston, Texas, and additional offices in Spain and China, Pyxis Lab serves over 25,000 installations worldwide, providing robust solutions for smart fluid management, chemical dosing and process control.

The inline smart sensor platform offered by Pyxis Lab Inc. is ideal for utilization in water and coolant fluid quality monitoring of Critical equipment in all segments of the CDU. All Pyxis sensors are 24V DC powered with an average of <1.5W demand have fully integrated transmitters within the sensor body/PCB itself, eliminating the need for any external displays, data loggers or transmitters. This makes the Pyxis line ideal for ease of integration with direct analog and digital (RTU) communication to the site DCS or PLC.

The Pyxis sensor platform is also produced in 316L stainless steel capable of operating at pressures as high as 290psi while installed in the ST-009 series stainless steel flow assembly options. This streamlines installation allowing easy sensor removal for calibration maintenance while ensuring the materials are fully compatible with all segments of the CDU including the Condenser Water System, Facilities Water System and Technology Cooling System.

## Pyxis Lab® Smart Sensor Innovations

Find below an overview of the most utilized sensors for critical coolant distribution units in the AI server market.

Product	Part #	Measured Analyte	Measurement	Material	Install Format
CR-300	51007	LPR Corrosion	General MPY/Pit Index	316L Stainless	ST-009 ¾-inch NPT
ST-710SS	53030	pH	pH	316L Stainless	ST-009 ¾-inch NPT
ST-711SS	53031	ORP	mV	316L Stainless	ST-009 ¾-inch NPT
ST-712SS	53032	pH + ORP	pH / mV	316L Stainless	ST-009 ¾-inch NPT
ST-720SS	58761	Temp + Conductivity	1 – 100,000µS/cm	316L Stainless	ST-009 ¾-inch NPT
ST-724	10009	Temp + Conductivity	0.02 – 1,000 µS/cm	316L Stainless	ST-009 ¾-inch NPT
ST-725	53108	Temp + Conductivity	0.02 – 200.0 µS/cm	316L Stainless	ST-009 ¾-inch NPT
ST-728	53117	Temp + Conductivity	0.02 – 10 µS/cm	316L Stainless	ST-009 ¾-inch NPT
ST-500SS-T	50661	PTSA Tracer	0 – 300 ppb	316L Stainless	ST-009 ¾-inch NPT
ST-587SS-T	54386	PTSA + Turbidity	0-300ppb / 0-200NTU	316L Stainless	ST-009 ¾-inch NPT
ST-588SS-T	53146	PTSA + Tag Polymer	0-300ppb / 0-20ppm	316L Stainless	ST-009 ¾-inch NPT
ST-565T-SS	56080	TTA/BTA Inhibitor	0.00 – 10.00 ppm	316L Stainless	ST-009 ¾-inch NPT
ST-730SS-T	56377	Turbidity	0.0 – 100.0 NTU	316L Stainless	ST-009 ¾-inch NPT
ST-730BSS-T	51119	Turbidity	0 – 1,000 NTU	316L Stainless	ST-009 ¾-inch NPT
ST-731SS-T	55995	Turbidity	0.00 – 10.00 NTU	316L Stainless	ST-009 ¾-inch NPT
RT-110L	57682	Ethylene/Propylene Glycol	0.0 – 20.0 ppm	316L Stainless	ST-009 ¾-inch NPT
SP-395T	50209	TTA/BTA Inhibitor	0.00 – 10.00 ppm	PBT	N/A
IK-1500	41179	pH + Cond + Turb+ Glycol			Full Panel Solution

## Pyxis Lab® Smart Sensor Innovations - Continued.

Find below an overview of the most utilized sensors for critical coolant distribution units in the AI server market.

### CR-300 Corrosion Rate Sensor



A 24V DC powered LPR corrosion sensor for wired connectivity to a controller, PLC or DCS network. The CR-300 offers integrated 4-20mA & RS-485 outputs and wireless connectivity when used with the MA-CR adapter for configuration on uPyxis®. The CR-300 provides instantaneous General & Localized corrosion output signals to the receiving device.

0.001–10MPY

### 0–14 pH / ±1,500mV ORP

A stainless steel pH + ORP sensor platform that offers a replaceable front-loading electrode head assembly for simple maintenance. The ST-712SS offers automatic temperature compensation and dual 4-20mA & RS-485 Modbus outputs for connection to any controller, PLC or DCS network. The ST-710SS (pH) & ST-711SS (ORP) offer the same build and single parameter measurements.



### ST-712SS pH + ORP Sensor

### ST-72X-SS Conductivity Sensors

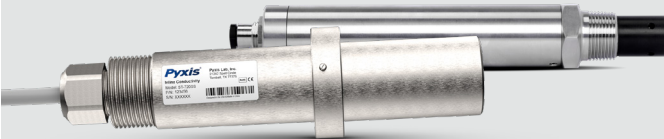

Our stainless steel Conductivity sensor series offer a robust stainless steel & hastelloy sensor construction with ¾in NPT threaded or tee-insertion installation options.

The ST-72XSS Series model all of our other sensor platforms with dual 4-20mA & RS-485 Modbus outputs for Conductivity & Temperature.

[Check Specifications for Ranges](#)

These sensor platforms offer a variety of installation formats with a rather small footprint. The sensors offer standard ¾in NPT thread for direct-insertion but also offer a tee-ready design for optimal maintenance.

Enabling the water treatment professional to remove and maintain their sensor without the need to shutdown their system allows for rapid cleaning & calibration without impacting the application. This sensor format is available in a multitude of key parameters for data center cooling applications including:

**ST-500SS-T** PTSA

**ST-587SS-T** PTSA + Turbidity

**ST-588SS-T** PTSA + Tagged Polymer

**ST-730SS-T** Turbidity

**ST-730BSS-T** Turbidity

**ST-731BSS-T** Turbidity

### ST-XXXSS-T Series Sensors



0.00–10.00ppm

ST-565T-SS & SP-395T are azole meters, Proper azole levels help protect copper and other metal components within the cooling loop from corrosion, extending equipment life and preventing cost-ly downtime. Continuous monitoring of azoles ensures that corrosion inhibitors remain within their effective ranges, preserving thermal performance and preventing system degradation that can lead to overheating or reduced cooling efficiency.



ST-565T-SS & SP-395T TTA/BTA Measurement

### RT-110L Inline Refractometer



An inline digital refractometer that measures the refractive index of a liquid sample and provides a direct reading of highly accurate concentration values for wide variety of water and process related applications. The RT-110L Inline Refractometer fully integrated 4-20mA and RS-485 Modbus output signals for connectivity to any PLC, display, microprocessor-based controller or DCS network. The RT-110L has built-in temperature dependent equations to convert the measured sample temperature and refractive index to the percentage concentration.

Ethylene/Propylene Glycol 0.00–100.00%

0–14 pH / 0–100 NTU / 0–100.00% Glycol / 10–10,000 uS/cm

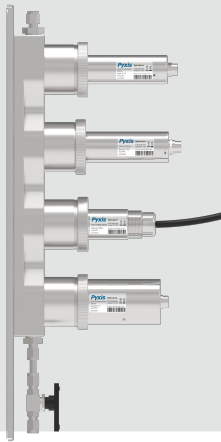

The IK-1500 liquid-cooled online analyzer is mainly used for online monitoring of liquid cooling in data centers (TCS). It is a pre-assembled multi-parameter analyzer that integrates pH, conductivity, turbidity, and glycol/propanediol concentration meters, aiming to provide a highly integrated solution for the monitoring of cooling fluids in high-challenging TCS. This product can accurately and repeatedly measure various online parameters of the cooling fluid in real time, and can also be expanded to include monitoring parameters such as copper corrosion inhibitor, corrosion rate, or pitting corrosion as per the on-site needs.

The IK-1500 probes housing is made of SS316L material, with a maximum pressure resistance of up to 290 PSI (2.0 MPa). It also adopts an integrated design of sensor and transmitter, with built-in RS-485 RTU & 4-20mA dual signal output. The equipment is compact in size and more convenient for integration into the CDU.

IK-1500 Liquid Cooling Monitoring Kit

## Stainless Steel Flow Cell Dimensions (mm)

ST-009 Single Sensor Flow Cell

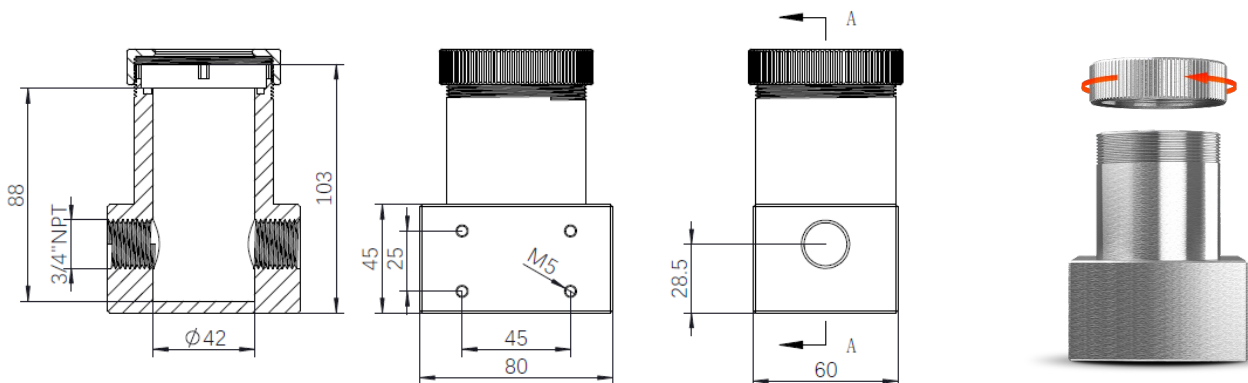

## Stainless Steel Flow Cell Dimensions (mm) - Continued

ST-009-02 Dual Sensor Flow Cell

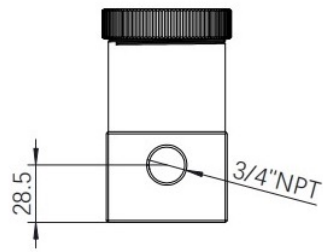
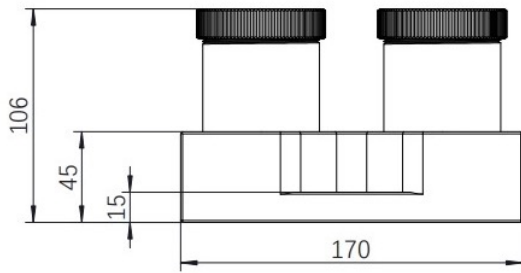

ST-009-03 Three Sensor Flow Cell

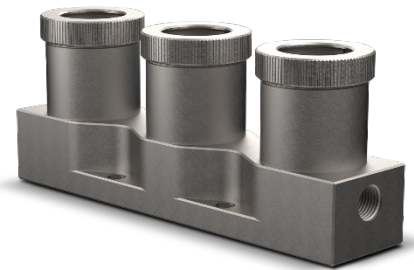
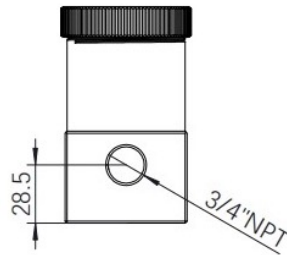
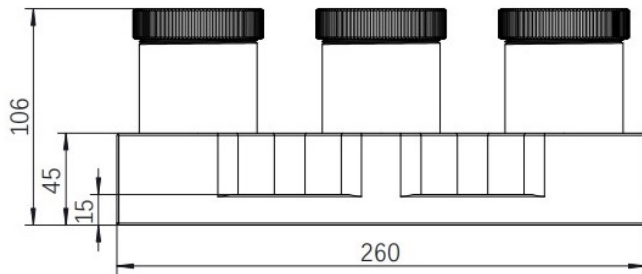

ST-009-04 Four Sensor Flow Cell

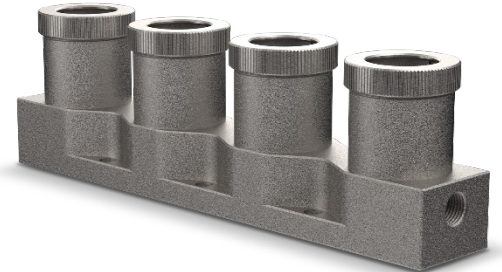
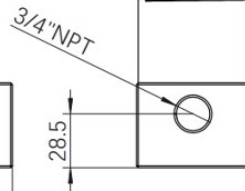
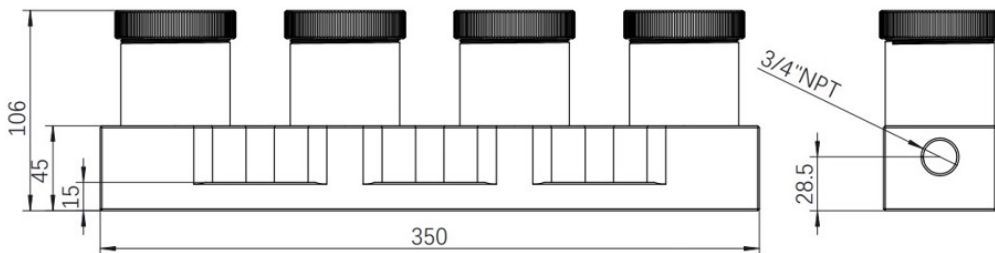

## Sensor Dimensions (mm)

ST-XXXSS-T Sensor Platform

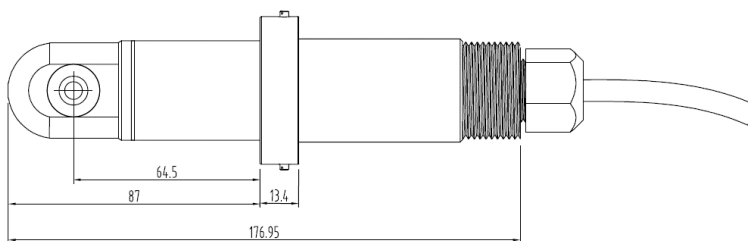
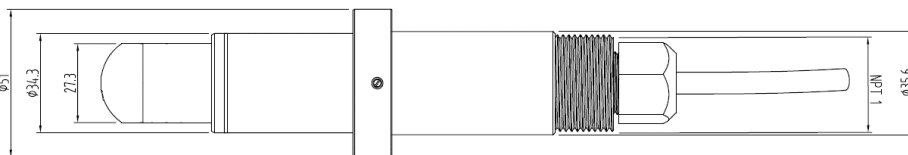



## Kit Dimensions (mm)

*IK-1500 Liquid Cooling Monitoring kit*

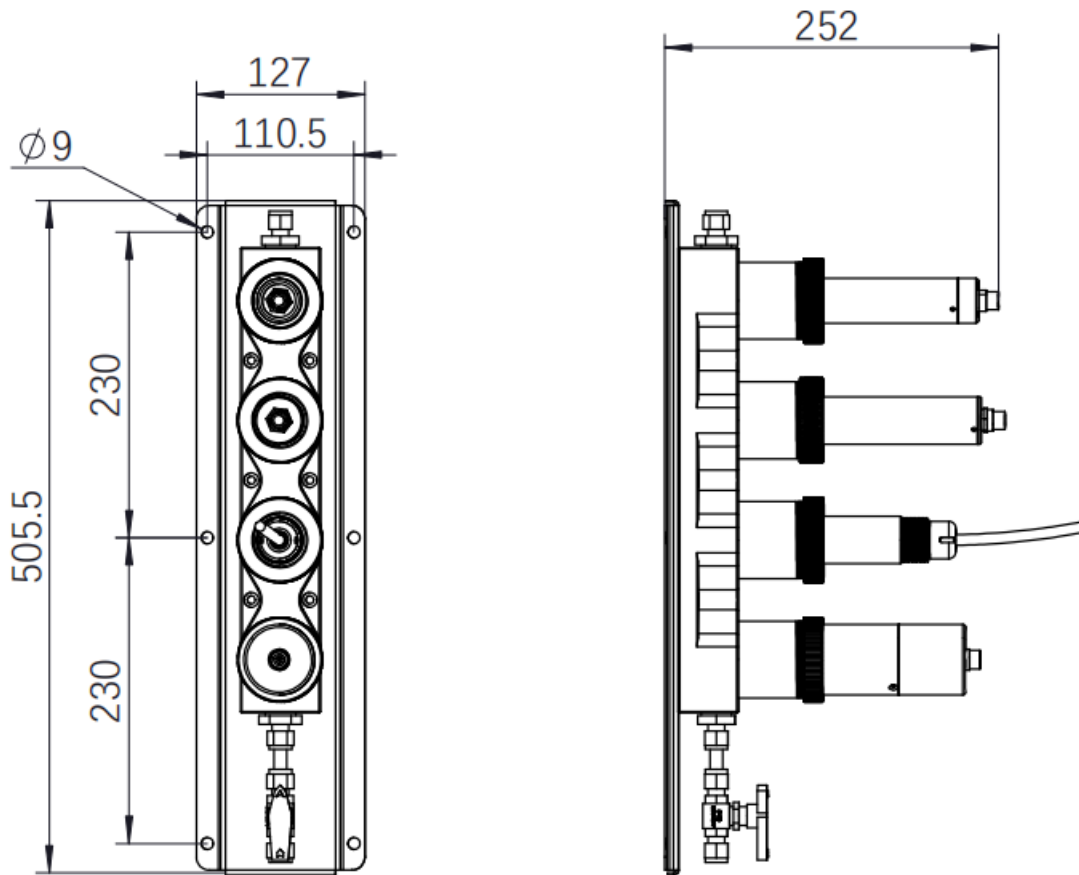

### HOW TO CONTACT PYXIS LAB® INC.

To learn more about Pyxis Lab smart sensor technologies ideally suited for this critical infrastructure contact us at [order@pyxis-lab.com](mailto:order@pyxis-lab.com) or [info@pyxis-lab.com](mailto:info@pyxis-lab.com) or by visiting our website at [www.pyxis-lab.com](http://www.pyxis-lab.com).